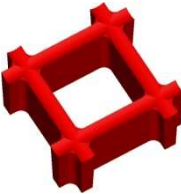
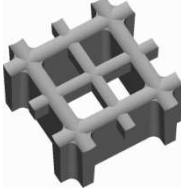
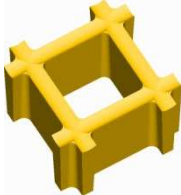
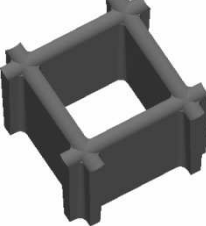

Load and deflection table

Panel type SIZE [mm]	Span [mm]	Concentrated load "F" Whole panel, 1% deflection (for an appropriate span) [kg]	Uniform distributed load q_s [kg/m ²]			Line Load Loading q_L Calculated on length 305mm 1% deflection (for an appropriate span) [kg / 305 mm]	
			Any panel 1% deflection (for an appropriate span)	Max. recommended			critical
				ISO-FR FD-FR (for an appropriate span)	VE-FR (for an appropriate span)	Do not use for design! It is critical destructive loading	
Mesh: 38 x 38 Thickness: 26 	300	1136	7347	7956	15545	34800	506
	400	738	3214	4478	8746	19744	288
	500	529	1693	2868	5598	12721	186
	600	402	1002	1992	3888	8882	130
	700	319	644	1464	2857	6556	96
	800	261	438	1121	2187	5039	74
	900	219	313	886	1728	3996	59
	1000	187	231	718	1400	3247	48
	1100	162	176	594	1157	2691	40
	1200	141	137	499	972	2267	33
	1300	116	109	425	829	1936	26
	1400	96	88	367	714	1673	-
	1500	81	72	319	622	1461	-
Mesh: 19 x 19 Mesh: 38 x 38 Thickness: 30 	300	1400	14844	13379	26141	58519	865
	400	998	6664	7989	15602	35223	518
	500	767	3581	5356	10455	23759	348
	600	619	2155	3863	7539	17223	251
	700	517	1403	2931	5717	13121	191
	800	441	968	2307	4499	10366	150
	900	384	697	1868	3642	8421	122
	950	361	600	1695	3306	7655	111
	1000	339	520	1546	3015	6992	101
	1100	303	399	1304	2541	5910	85
	1200	274	313	1115	2174	5069	73
	1300	249	250	966	1883	4401	63
	1400	229	204	846	1649	3862	55
Mesh: 38 x 38 Thickness: 38 	300	2190	26809	14278	38807	61369	1288
	400	1533	10599	8031	21830	37082	758
	500	1162	5163	5139	13971	25088	502
	600	927	2867	3569	9703	18231	359
	700	765	1744	2622	7129	13918	270
	800	648	1135	2007	5458	11016	211
	900	560	776	1586	4312	8963	170
	1000	492	552	1285	3493	7453	140
	1100	437	406	1062	2887	6307	117
	1200	389	305	892	2426	5416	100
	1300	325	217	760	2067	4708	86
	1400	275	182	655	1782	4135	75
	1500	236	146	571	1553	3664	66
Mesh: 50 x 50 Thickness: 50 	300	2734	46840	31583	31583	59419	2618
	400	2077	18922	17766	17766	37886	1593
	500	1677	9371	11371	11371	26722	1084
	600	1409	5278	7897	7897	20091	791
	700	1216	3247	5802	5802	15786	606
	800	1070	2132	4442	4442	12810	481
	900	956	1472	3510	3510	10654	393
	1000	864	1056	2843	2843	9035	328
	1100	789	782	2350	2350	7784	278
	1200	720	590	1974	1974	6793	239
	1300	616	423	1682	1682	5994	208
	1400	533	357	1451	1451	5337	183
	1500	466	287	1264	1264	4791	163

Instructions for Load and deflection table

Loading type: Concentrated load

Table column "**Concentrated load F of whole panel, 1% deflection (for appropriate span)**" is giving the concentrated load data causing a deflection of 1% at an appropriate span. The load is applied at the centre of a whole panel (area 200mm x 200mm), which is supported on two sides. This table is only valid for the **uncut panels**. If bigger deflection is allowed, just multiply the specified percentage deflection with the 1% load data. Deflection is proportional with load.

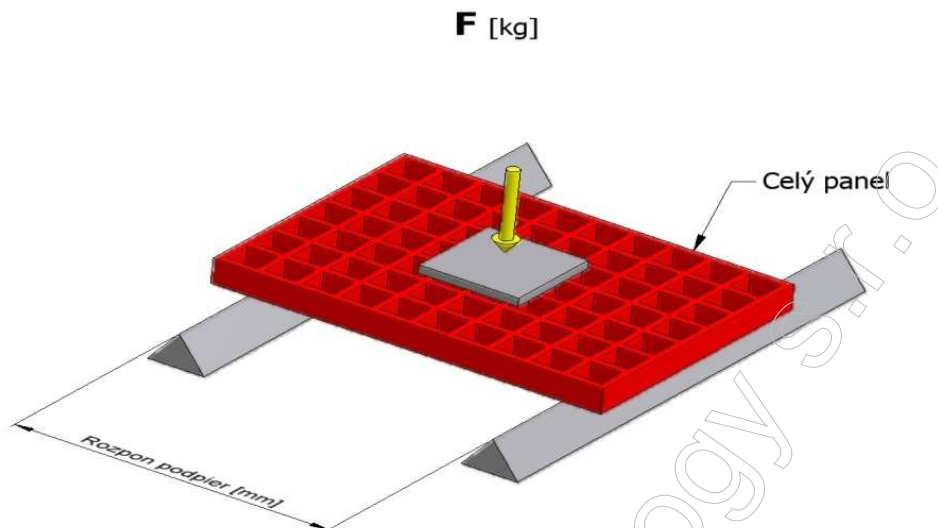

Loading type: Uniform distributed load

Table column "**Uniform distributed load of any panel, 1% deflection (for appropriate span)**" is giving the uniform load data causing a deflection of 1% at an appropriate span. This table is valid for all panels, also for the **cut panels**. If bigger deflection is allowed, just multiply the specified percentage deflection with the 1% load data. Deflection is proportional with load.

Table column "**Max. recommended uniform distributed load for appropriate gratings types**" (ISO-FR, FD-FR or VE-FR) is giving maximal uniform load data. It is information for designer, when he design gratings not according to deflection but according to load capacity.

Table column "**Critical uniform distributed load**" is giving the uniform load data causing a gratings destruction. Do not use it for design!

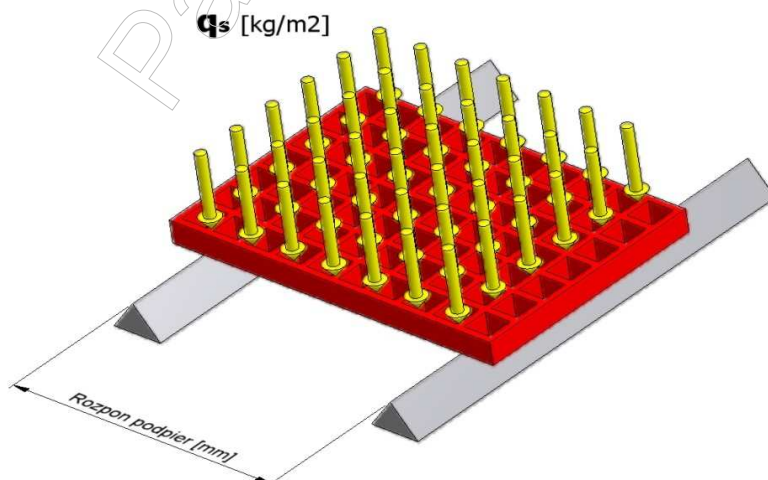

Loading type: **Line load**

Table column " **Line load q_L calculated on length 305mm, 1% deflection (for appropriate span)**" is giving the line load data causing a deflection of 1% at an appropriate span. This table is valid for all panels, also for the **cut panels**. The load is applied at the centre of this strip.

For gratings with a larger width, the load can easily be calculated by multiplying the width with the given load, divided by 305 mm.

If bigger deflection is allowed, just multiply the specified percentage deflection with the 1% load data. Deflection is proportional with load.

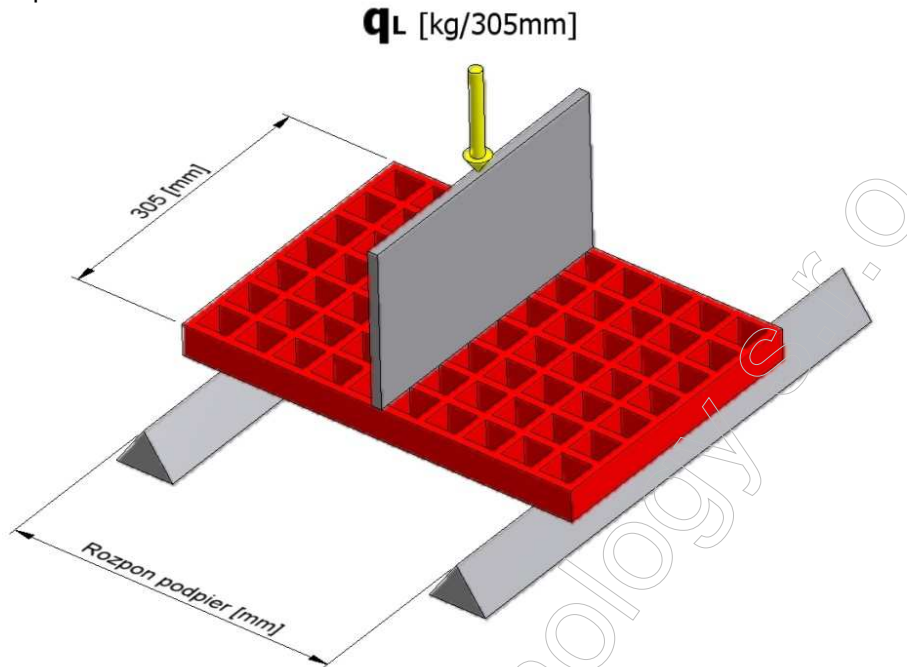

Some recommendations for installation

- **Recommended minimal width of contact area:**

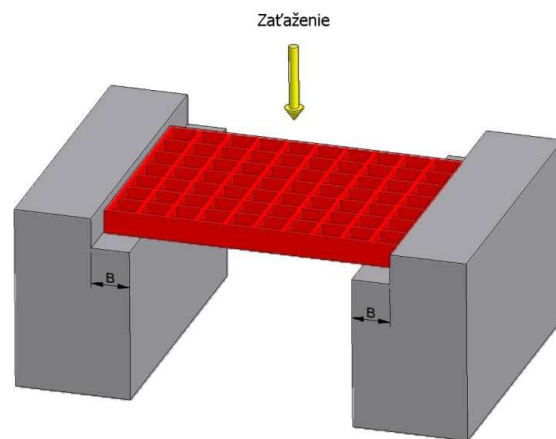

Panel thickness	Contact area width "B"
26 mm	30 mm
30 mm	30 mm
38 mm	40 mm
50 mm	50 mm

- **Grate installed as shaft cover:**

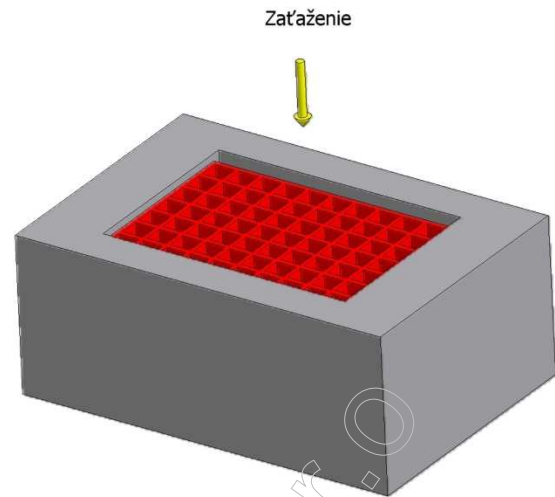

Panel thickness	Max. recommended span
26 mm	600 mm
30 mm	1000 mm
38 mm	1100 mm
50 mm	1400 mm

Pápay Technology s.r.l.